

STRAIN MEASUREMENT BY USING PHASE MODULATED FIBER OPTIC SENSORS TECHNOLOGY

Riadh Adnan Kadhim

Assistant lecturer, Electromechanical Engineering Department, University of Technology

(Received: 5/6/2012; Accepted: 25/12/2012)

ABSTRACT: - This paper deals with simulation using (MATLAB) of optical fiber strain sensor employing the phase modulated technique in order to design a model for the Michelson interferometer, this paper also deals with the implementation of interferometer technique is considered and simplified because it has the ability to convert phase modulation to intensity modulation, in addition it has the ability to perform modulation frequency of interest signal which is equal to the optical frequency of the source.

Thus by using this technique the detection of the signals of interests is achieved. The obtained results of sensor are done by varying the applied forces of sensing element, having various core diameters and calculating the strain. Also the result shows that the fiber optic Michelson sensor is very sensitive to measure the structural strain.

Keywords: Fiber optic, Strain measurement, phase modulated.

1- INTRODUCTION

The practical applicability of fiber optic sensors was widely recognized over 20 years ago. Since then, the further development and implementation of these sensors has been driven by the versatility and properties inherent to optical fiber, as well as by the maturation of the fiber and device technologies associated with the telecommunications industry. ⁽¹⁾ Attractive qualities of optical fiber include a dielectric composition which results in immunity to electromagnetic interference and ground loop networking problems. ⁽²⁾

The ability to support high bandwidth signals required for multiplexing numerous high-performance sensors, and the possession of a small size and a sturdy composition which allows them to be integrated directly into materials. ⁽³⁾

The flexibility and sensitivity of sensors fabricated from optical fiber permits the measurement of a variety of phenomena, including temperature, pressure, strain, and degree of cure, chemical content, viscosity, acoustic waves, magnetic fields, and degree of rotation.

(2, 3)

The design of the sensor system determines whether the external perturbation modulates the amplitude, phase, differential phase, or spectral distribution, of the optical carrier. Amplitude modulation directly affects the signal intensity, phase modulation is converted to intensity modulation through interferometer, differential phase modulation is converted to intensity through the determination of polarization, and modification of spectral distribution may be determined through spectroscopic analysis. ⁽⁴⁾

Fiber optic sensors are commonly constructed from silica-based glass optical fibers ⁽³⁾ When standard telecommunications fiber is used, sensor systems benefit from low optical signal transmission loss of the optical fiber, an optical signal well confined to the waveguide, and the low cost and wide availability of the optical fibers. ⁽⁴⁾

Optical fibers frequently have a protective coating of acrylate, but they may also be encased in polyimide, metal, carbon, or some other protective jacket. This outer coating preserves the physical strength of the optical fiber by providing protection from the environment. Without the coating, the glass waveguides are exposed to moisture which causes significant weakening of the fiber. ⁽³⁾

1.1 FIBER OPTICS SENSORS

The fiber sensor is illustrated diagrammatically in Figure (1). The basic components are simple. Light is taken to a modulation region using an optical fiber and modulated there in by physical, chemical, or biological phenomena, and the modulated light is transmitted back to a receiver (detected, and demodulated). Hopefully, there is a one-to-one correlation between the phenomenon of interest and the demodulated signal. There are two substantial issues in realizing a viable optical fiber sensor technology. ⁽⁵⁾

1- To ensure the one-to-one relationship between the parameters to be measured and the demodulated signal.

2- To match the technology to the application in terms of both performance and cost.

The first of these is the simpler one despite the fact that the impact of the fibers to words from the modulation region, variations in source and detector characteristics with temperature and time and the influence of temperature on the modulation process are all important. The second of these must recognize the presence of established techniques and in particular must identify otherwise insoluble problems which are important but for technical reasons Have not been satisfactorily resolved. ⁽⁵⁾

1.1.1 FIBER OPTIC SENSOR CONFIGUARTIONS

Fiber optic sensors (FOS) can be generally classified in two large groups:

- 1) Extrinsic FOS
- 2) Intrinsic FOS

Extrinsic FOS is basically optical sensor where the lights signal is delivered by optical Fiber, while the modulation of the light signal occurs outside optical fiber. Till now, sensors present most successfully commercial FOS. Typical examples are fiber versions of Doppler anemometers and non-contact vibration measurements systems. ⁽⁶⁾ These sensors tend to be rather expensive and are used in industries such as aerospace and automotive. Their major advantage is that the flexible and dielectric link provided by the fiber allows the instruments to be used where access is difficult or prohibitive by means of electrical signals. Intrinsic FOS is (true) fiber optic sensors, meaning that the modulation of light takes place inside fiber in accordance to measured parameter. According to principle of operation both sensor groups can be further divided in two large categories. ⁽⁶⁾

1- Intensity modulated FOS

2- Phase modulated FOS (fiber interferometers)

1.1.2 PHASE MODULATED FOS

The most sensitive fiber–optic sensors are based on optical phase modulation. They generally require single–mode fiber and other single– mode optical components such as coherent sources (Lasers). The source optical frequency is approximately 1014Hz. The frequency response of photo detectors is significantly less, and therefore they cannot be used to directly measure phase modulation. However, the modulation frequency associated with signal of interests is many orders of magnitude lower than the optical frequency. Thus by using optical interferometer which converts phase modulation to intensity modulation, the detection of the signals of interest is accomplished. A variety of interferometers is shown in Figure (2). ⁽⁷⁾

As an example, consider the case of the Mach-Zehnder interferometer shown in Figure (2.a) the output of a single-mode laser is coupled into the optical-fiber lead. The light coupled into lead fiber is split by a 3-dB coupler/splitter(C/S) into two arms of the interferometer. In the case of the Michelson and Sagnac interferometers shown in Figure (2.b) and (2.d) single C/S serves identically as the input and output C/S. In the case of the Fabry-Perot interferometer, a partially reflecting mirror is used to split and recombine the light. ⁽⁷⁾

2 OPTO-MECHANICAL EFFECTS:

The transduction mechanism by which a fiber – optic axial strain produces a phase change in the optical path length. The phase ϕ of the light can be expressed by Equation (1). ⁽⁸⁾

$$\phi = KnL \dots\dots\dots (1)$$

where ϕ is in radians, K is the wave number $2\pi/\lambda$, λ is the free – space wavelength of the light and n is the fiber core refractive index and L is the length of fiber in the sensor. A mechanical force applied to the fiber results in changing in n and L , and, therefore, in ϕ the corresponding expression relating these changes is. ⁽⁸⁾

$$\Delta\phi = K\Delta(nL) = KnL\left(\frac{\Delta n}{n} + \frac{\Delta L}{L}\right) \dots\dots\dots (2)$$

$$\frac{\Delta L}{L} = \epsilon_{11} \dots\dots\dots (3)$$

Where ϵ_{11} is the axial strain, and

$$\frac{\Delta n}{n} = \frac{n^2[(p_{11} + p_{12})\epsilon_{12} + p_{12}\epsilon_{11}]}{2} \dots\dots\dots (4)$$

In equation (3), p_{11} and p_{12} are Poisson coefficient and ϵ_{12} is the radial strain due to an axial stress. In fused silica $p_{11} = 0.12$, $p_{12} = 0.72$, $n = 1.46$, and the strains ϵ_{11} and ϵ_{12} are related by.

$$\epsilon_{12} = -\mu\epsilon_{11} \dots\dots\dots (5)$$

where μ is Poisson's Ratio: Substituting equation (4) and (5) into equation (2) yields

$$\Delta\phi = KnL\left\{\frac{1 + n^2[(1 - \mu)p_{12} - \mu p_{11}]}{2}\right\}\epsilon_{11} \dots\dots\dots (6)$$

Thus, a strain in the sensing fiber caused by the physical parameter of interest induces a proportional phase change in the optical fiber. Equation (6) is the fundamental design equation for many interferometric fiber-optic sensors.

The elastic properties of the fused silica can be described using elastic moduli that derived from the tensors of the material. Usually, the elastic properties of materials are expressed in terms of engineering moduli: Young's modulus E , shear modulus G , bulk Modulus B and Poisson's ratio μ . The Young's modulus and Poisson's ratio are defined as :⁽⁸⁾

$$E = \frac{\text{stress}}{\text{strain}} = \frac{F/A}{\Delta L/L} \dots\dots\dots (7)$$

$$\mu = \frac{\text{lateral strain}}{\text{longitudinal strain}} = -\frac{\epsilon_x}{\epsilon_z} \dots\dots\dots (8)$$

where F is the force applied, A the cross-sectional area over which the force is applied, and ϵ is strain. The Young's modulus and Poisson's ratio are 95GPa and 0.17 respectively for fused silica

1.2.1 DEFINITIONS OF STRIAN

The concepts of stress and strain are introduced in the context of a long homogeneous isotropic bar subjected to a tensile load. The stress σ is the applied force F , divided by the cross-sectional area A . The resulting strain ϵ is the length change ΔL , divided by the initial length L . The bar elongates in the direction the force is pulling (longitudinal strain ϵ_L) and contracts in the direction perpendicular to the force (transverse strain ϵ_t).⁽⁹⁾

Stress: Force per unit area arising from applied load. (Tension, compression, shear, torsion)

Strain: physical deformation response of a material to stress, elongation.⁽⁹⁾

$$\text{Stress} \quad \sigma = \frac{F}{A} \quad \text{Units: } \sigma \text{ [MPa]} \quad \dots\dots\dots (9)$$

Where F is the applied force, A the cross-sectional area

Modulus of Elasticity (E) Units: E [GPa] or [psi]: (Also known as Young's modulus)

$$\text{Hook's Law} \quad \sigma_T = E \epsilon \quad \dots\dots\dots (10)$$

$$\text{Strain} \quad \epsilon = \frac{\Delta L}{L} \quad \text{Units: } \epsilon \text{ [micro strain]} \quad \dots\dots\dots(11)$$

where ΔL length change (elongation), L the initial length

When the strain is not too large, many solid materials behave like linear springs; that is, the displacement is proportional to the applied force. If the same force is applied to a thicker piece of material, the spring is stiffer and the displacement is smaller. This leads to a relation between force and displacement that depends on the dimensions of the material. Material properties, such as the density and specific heat, must be defined in a manner that is independent of the shape and size of the specimen. Elastic material properties are defined in terms of stress and strain. In the linear range of material response, the stress is proportional to the strain. The ratio of stress to strain for the bar under tension is an elastic constant called the Young's modulus E. The negative ratio of the transverse strain to longitudinal strain is the Poisson's ratio μ See Figure (3, 4).⁽⁹⁾

3 MICHELSON INTERFEROMETER SENSORS

The fiber optic Michelson interferometer consists of a single-mode fiber directional coupler with reflection mirrors formed on the cleaved ends of both fibers on the same side of the coupler as one of the fibers is used as a reference fiber and the other is used to sense structural parameter. Any deformation in a transportation infrastructure will result in a change in the length difference of the two fibers .that very small changes of length produce large phase differences. Similarly, very small changes of refractive index at longer sections of fiber L produce large phase differences. Is called optical path difference (OPD).⁽¹⁰⁾

The Optical phase change cannot be directly detected in order to detect phase difference it necessary to convert phase difference to optical intensity change. This is achieved by combing (mixing) two optical signals. The whole system is called interferometer and the most straightforward configuration, called Michelson interferometer, is shown in Figure (5).

In this configuration light wave is split and recombined in the same splitter. Fiber mirrors are used to reflect light at the fiber ends. One fiber is exposed to measured field, and is called sensing fiber. Another fiber is isolated from the surrounding and is called reference fiber. If the sensing fiber is unperturbed, then two fibers have exactly the same length L. If the sensing fiber experiences a mechanically or thermally applied strain, the optical length of sensing fiber increases and the optical path difference changes. The intensity output decreases due to destructive interference. ⁽¹⁰⁾

A typical output of a conventional fiber optic interferometry system is plotted in Figure. (6). the sensor has a maximum sensitivity at the points where $\Delta\phi = (2n-1)/\pi$ (n is an integer). These points of maximum sensitivity are known as quadrature points. However, the peaks and valleys of the sine curve show very little sensitivity, as a change in phase difference hardly affects the intensity of interference. Thus, the operations of sensors in these regions should be avoided if possible. In fact, these sensors are typically operated within a (linear)range in the vicinity of a quadrature point, and hence, they have limited dynamic range ($<\lambda/4$). In addition, the sensor operating point may suffer from drift due to environmental perturbations and light source wavelength fluctuations. ⁽¹¹⁾

The Michelson output intensity can be expressed as ⁽¹²⁾

$$I = I_1 + I_2 + 2\sqrt{I_1 I_2} \gamma(K, OPD) \cos \Delta\phi \quad \dots\dots\dots (12)$$

where I_1 and I_2 is the intensities of the two light beams and OPD is the optical path difference of the two beams. γ is the interferometer visibility, and $\Delta\phi$ is the Michelson bias phase offset, varying slowly and randomly with environmental conditions . The visibility function is defined as:

$$\gamma = \exp\left[-\left(\frac{OPD}{l_c}\right)^2\right] \quad \dots\dots\dots (13)$$

where l_c is the coherence length of the light source (the maximum achievable Visibility value is 1). The coherence length, an inherent property of a light source, is a function of the wavelength λ and the spectrum width $\Delta\lambda$ of the source, as shown below ⁽¹²⁾

$$l_c = \frac{\lambda^2}{\Delta\lambda} \quad \dots\dots\dots (14)$$

Subsequently, the visibility of the interference can be determined as

$$v = \frac{2\sqrt{I_1 I_2}}{I_1 + I_2} \gamma \dots\dots\dots (15)$$

The better the visibility, the higher the amplitudes of the interference fringe will be. From Equations (13) and (15), it can be seen that the OPD is critical in determining the visibility of the interference. Thus, in order for an interferometer to function properly with high visibility, it is generally necessary for the OPD to be much shorter than the coherence length of the light source. If this condition is met, the general output of a two beam interferometer can be simplified to the form

$$I = I_1 + I_2 + 2\sqrt{I_1 I_2} \cos \Delta\phi \dots\dots\dots (16)$$

4 RESULTS

By applying a force on the fiber sensing (SMF) having a length of (500mm), a stress is formed in which it could be calculate by the use of equation (9) .the resulting elongation from the generated strain leads to a change in the phase, the elongation may be calculate by equation (11), so by substituting the strain value in the resulted elongation equation (11), so the change in phase is obtained by using equation (6). The results of Stress (σ), strain (ϵ) and elongation (ΔL) are listed in Table (1, 2, and 3), (SMF) Single-Mode Optical Fiber, Wavelength (nm): 1310, Length sensor: 500 mm.

The results of Intensity variation with respect to the optical phase difference (SMF) Single-Mode Optical Fiber, Wavelength (nm): 1310, Length sensor: 500mm are listed in figure (10, 11, and 12).

5 CONCLUSIONS AND DISCUSSION

To study the sensor performance, selecting three different value for the fiber core diameter which h is (7.5, 9.4, 10.5) μm is preferable, concluding that whenever core diameter decreases, the Strain increases, as a result, so a clear phase change, as shown in figure (10, 11, 12). From the results of this work, the conclusions can be obtained. The Guided-wave optics, particularly fiber systems continue to offer unique possibilities in a measurement context the general drawback of FOS is the velocity ratio of cost/preference, however rapid development of telecommunication systems have important impacts on the lowering of the cost of the fiber optic components, which will eventually bring FOS to more diverse range of applications.

REFERENCES

- 1) Eric Udd, (1995) "An Overview of Fiber Optic Sensors", Rev. Sci. Instrumentation, American Institute of Physics, 66 (8).
- 2) Zubia, J, Arrue, (2001) "Optical Fibers, An Introduction to their Technological Processes and Applications", Invited Paper, Optical Fiber Technology, 7, pp.101-140.
- 3) B. E. A. Saleh and M.C. Teich, (1991) "Fundamentals of Photonics", John Wiley & Sons.
- 4) John Dakin and Brian Culshaw, Editors, (1988) "Optical Fiber Sensors", Principles and Components, Artech House.
- 5) Pinet É., Hamel C., Glišić B., Inaudi D. & Miron N., (2007) "Health monitoring with optical fiber sensors: from human body to civil structures" in Health Monitoring of Structural and Biological Systems, vol. 6532 of Proc. SPIE, pp. 653219-1 to 653219-12.
- 6) A. M´endez and T. S. Morse, Eds., (2007) "Specialty Optical Fibers Handbook", chapter 6.4, Elsevier, Amsterdam, the Netherlands, 1st edition.
- 7) B. Culshaw, (2000) "Fiber Optics in Sensing and Measurement", IEEE Journal of selected topics in quantum electronics, vol 6, pp.1014-1021.
- 8) L. Yuan, Z. Liu, J. Yang, and C. Guan, (2008) "Bitapered fiber coupling characteristics between single-mode single-core fiber and single-mode multicore fiber" Applied Optics, vol. 47, no. 18, pp. 3307–3312.
- 9) R. C. Craig, (1996) "Mechanics of Materials", New York, John Wiley & Sons.
- 10) Kashyap, R. and B. Nayar, (1983) "An all single-mode fiber Michelson interferometer sensor", J. Lightwave Technol., vol. 1, pp. 619-624.
- 11) M. Yu. (2002) "Fiber-Optic Sensor Systems for Acoustic Measurements", Ph.D. Dissertation, University of Maryland, College Park, MD.
- 12) Van Neste R., Belleville C., Pronovost D. & Proulx A. (2005) "System and method for measuring an optical path difference in a sensing interferometer" US patent 6,842,254 B2.

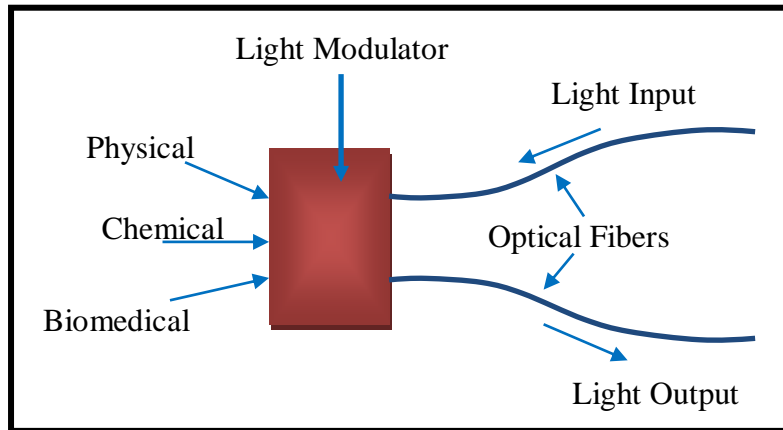

Figure (1): Basic function of the optical fiber sensors

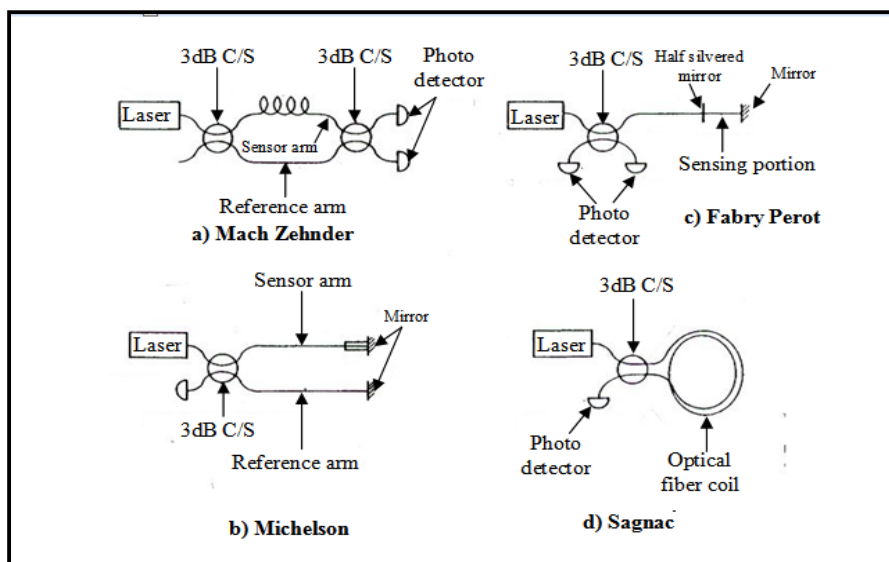

Figure (2): Fiber-optic interferometers

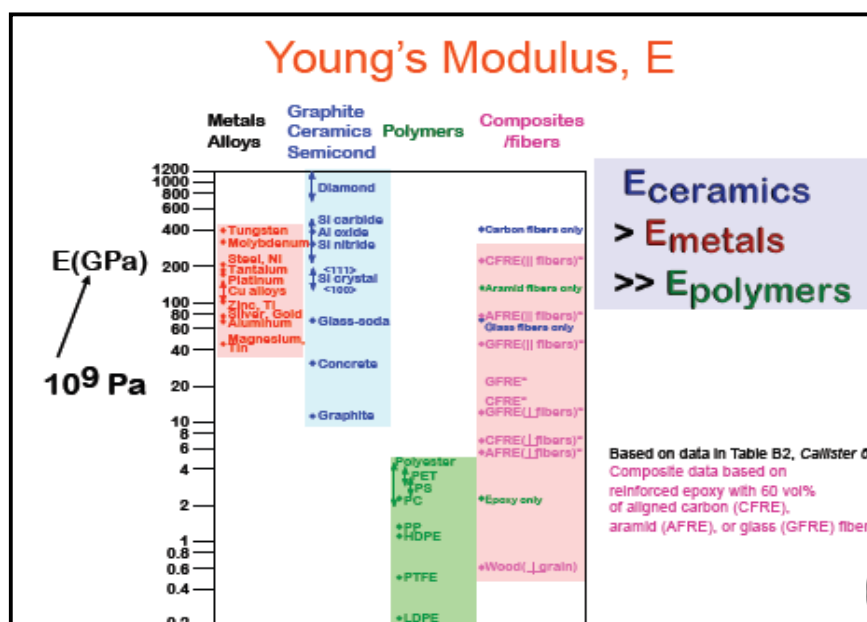

Figure (3): Young's Modulus for Material (E)

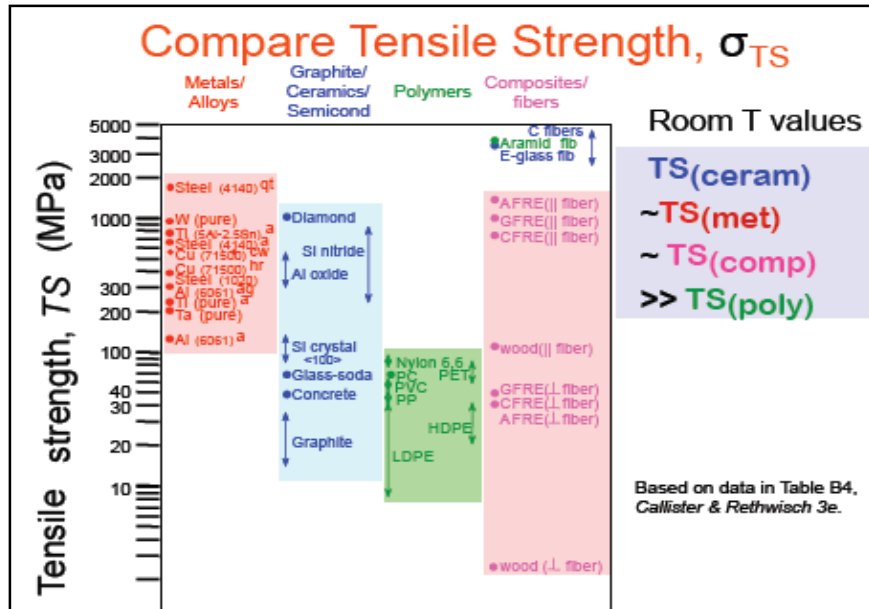

Figure (4) : Tensile strength for material (σ_T).

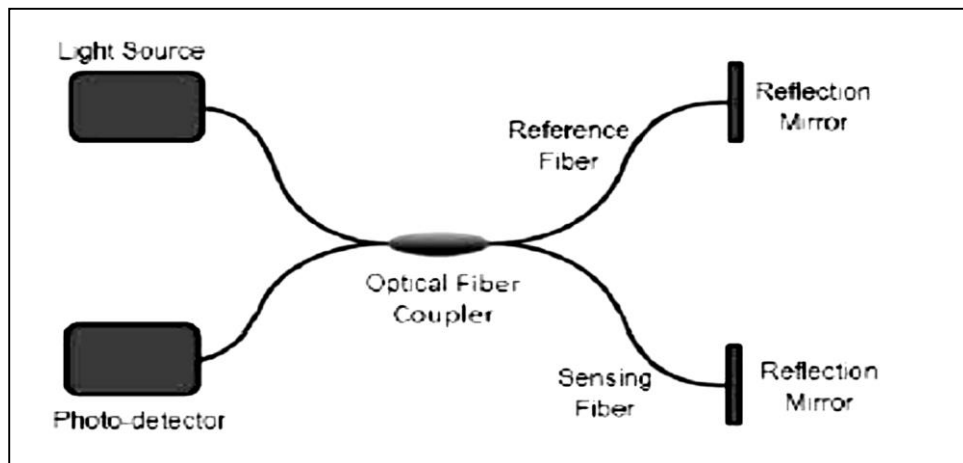

Figure (5): Fiber optic Michelson interferometer.

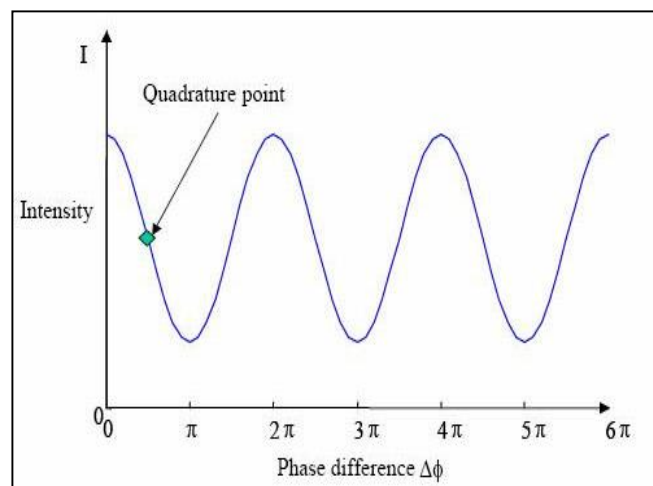

Figure (6): Intensity variation with respect to the optical phase difference.

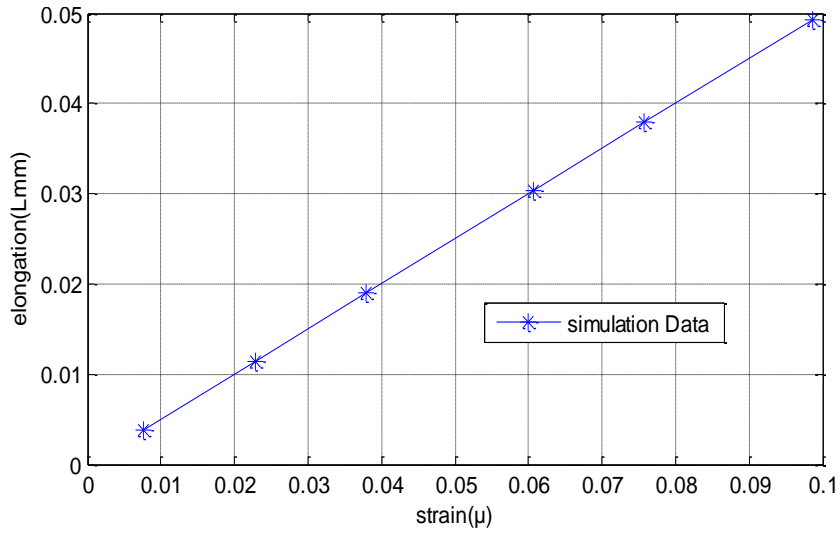

Figure (7): Elongation vs. Strain

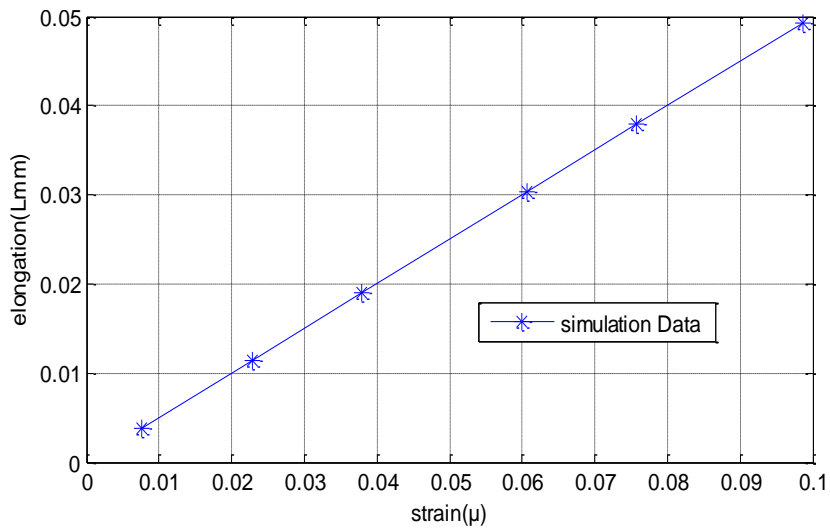

Figure (8): Elongation vs. Strain

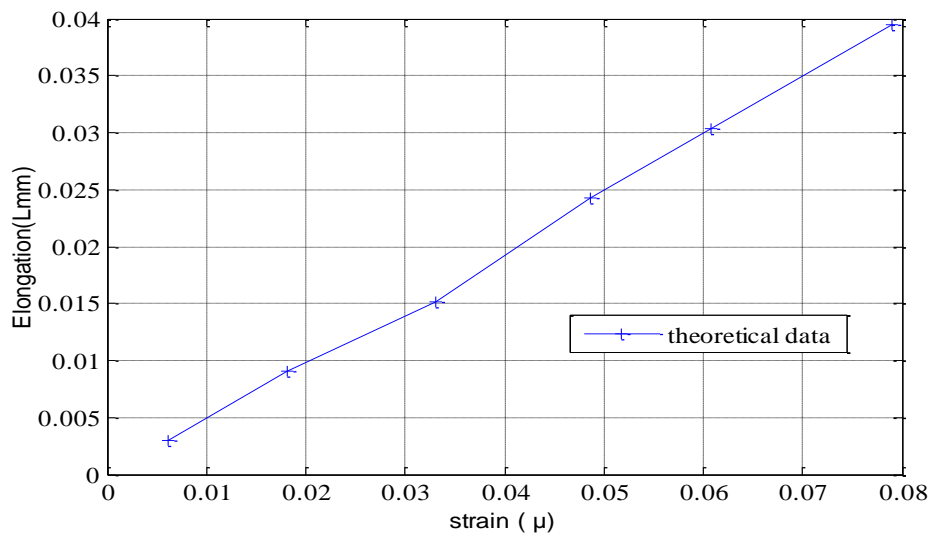

Figure (9): Elongation vs. Strain

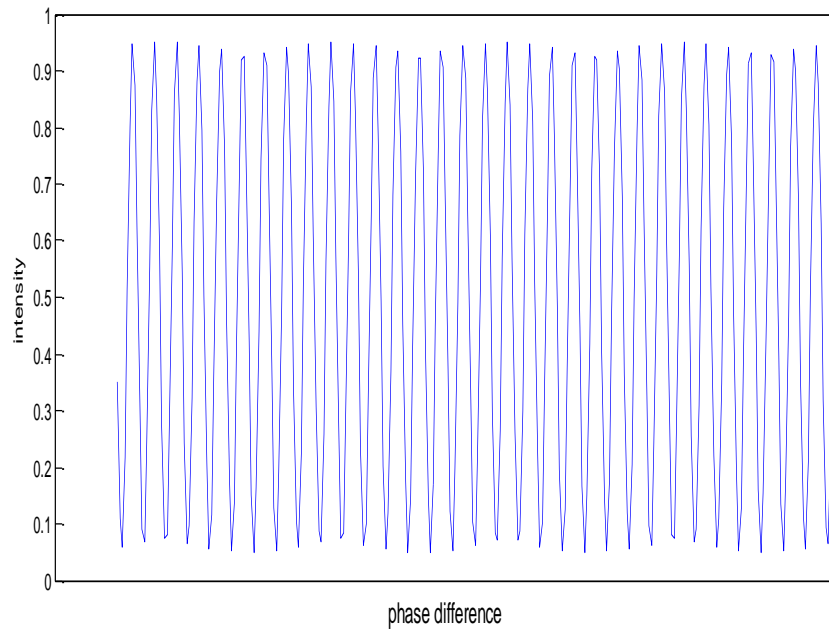

Figure (10): Intensity variation with respect to the optical phase difference When the core diameter ($7.5\mu\text{m}$)

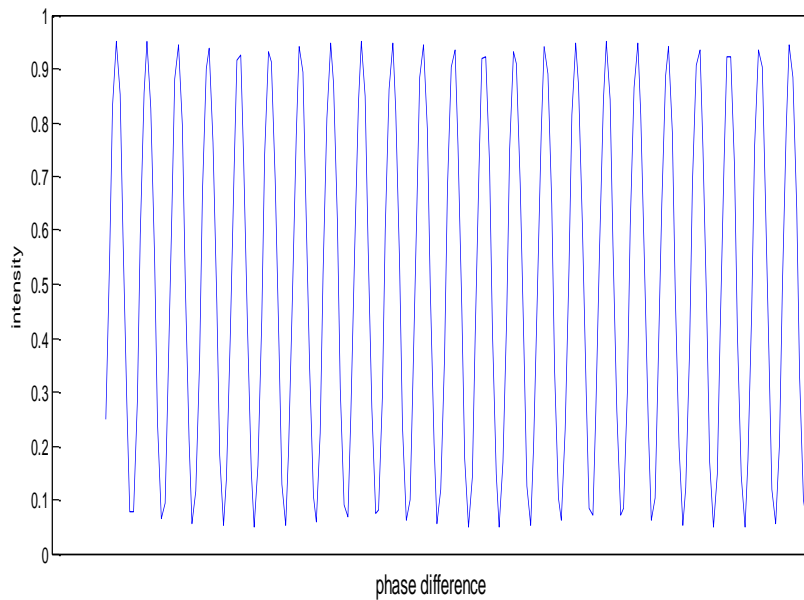

Figure (11): Intensity variation with respect to the optical phase difference When the core diameter ($9.4\mu\text{m}$)

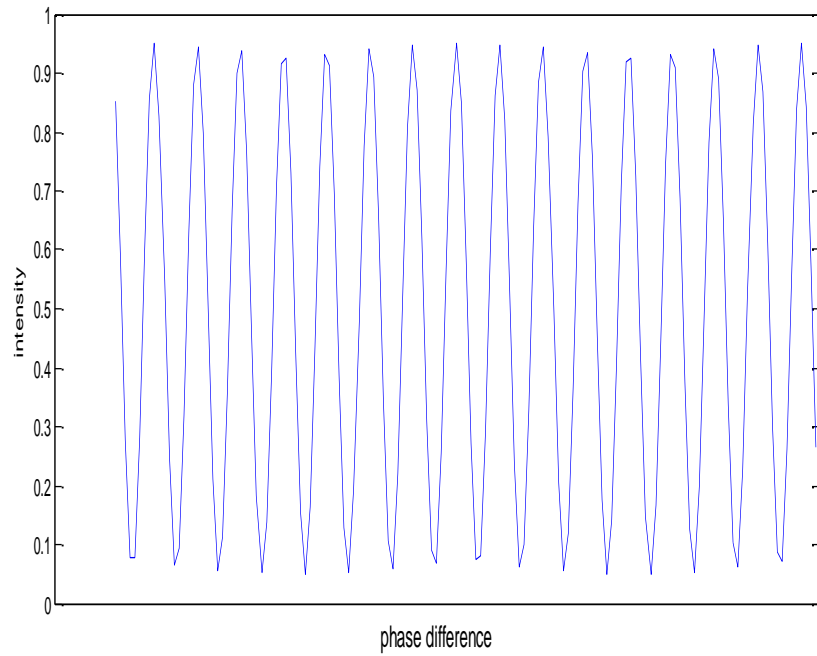

Figure (12): Intensity variation with respect to the optical phase difference When the core diameter (10.5 μ m).

Table (1): Stress (σ), strain (ϵ) and elongation (ΔL) core diameter (7.5 μ m)

F(N)	σ (N/m ²)	ϵ (μ strain)	ΔL (mm)
0.1	1.1318e+009	0.0119	0.0060
0.3	3.3953e+009	0.0357	0.0179
0.5	5.6588e+009	0.0596	0.0298
0.8	9.0541e+009	0.0953	0.0477
1.0	1.1318e+010	0.1191	0.0596
1.3	1.4713e+010	0.1549	0.0774

Table (2): Stress (σ), strain (ϵ) and elongation (ΔL) core diameter (9.4 μ m).

F(N)	σ (N/m ²)	ϵ (μ strain)	ΔL (mm)
0.1	7.2048e+008	0.0076	0.0038
0.3	2.1615e+009	0.0228	0.0114
0.5	3.6024e+009	0.0379	0.0190
0.8	5.7639e+009	0.0607	0.0303
1.0	7.2048e+009	0.0758	0.0379
1.3	9.3663e+009	0.0986	0.0493

Table (3): Stress (σ), strain (ϵ) and elongation (ΔL) core diameter (10.5 μ m).

F(N)	σ (N/m ²)	ϵ (μ strain)	ΔL (mm)
0.1	5.7743+008	0.0061	0.0030
0.3	1.7323e+009	0.0182	0.0091
0.5	2.8872e+009	0.03304	0.0152
0.8	4.6195e+009	0.0486	0.0243
1.0	5,7743e+009	0.0608	0.0304
1.3	7.5066e+009	0.0790	0.0395

قياس الجهد باستخدام تقنية مستشعرات الالياف البصرية المضمنة طوريا

رياض عدنان كاظم

مدرس مساعد، الجامعة التكنولوجية

الخلاصة:

في هذا البحث نعمل على دراسة محاكاة لتحسس (Strain) بواسطة أستعمال متحسس الليف البصري وذلك بمساعدة (MATLAB) يتم تطبيق (Phase Modulate Technique) وذلك لتصميم نموذج لمتحسس (Michelson). في هذا البحث تم أستعمال تقنية (Interferometer) لما لها من بساطة في تحويل (Phase Modulated) الى (Intensity Modulated) وكذلك ايضا لها القابلية لانجاز تردد التضمين المرافق للاشارة المرغوبة ليكون مساو للتردد البصري للمصدر وباستعمال هذه التقنية يمكن بسهولة تطبيق عملية كشف الاشارة المرغوبة. أيضا في هذا البحث تم العمل على أستحصال النتائج لمتحسس الليف الضوئي بواسطة تسليط قوة متغيرة على العنصر المتحسس ذو اقطار مختلفة (Core Diameter) و أحتساب (Strain). ومن هذه النتائج تم الحصول على متحسس ذو حساسية عالية (High Sensitivity)